

# Owner's Manual

## 25 Gallon Spot Sprayer Model LG25

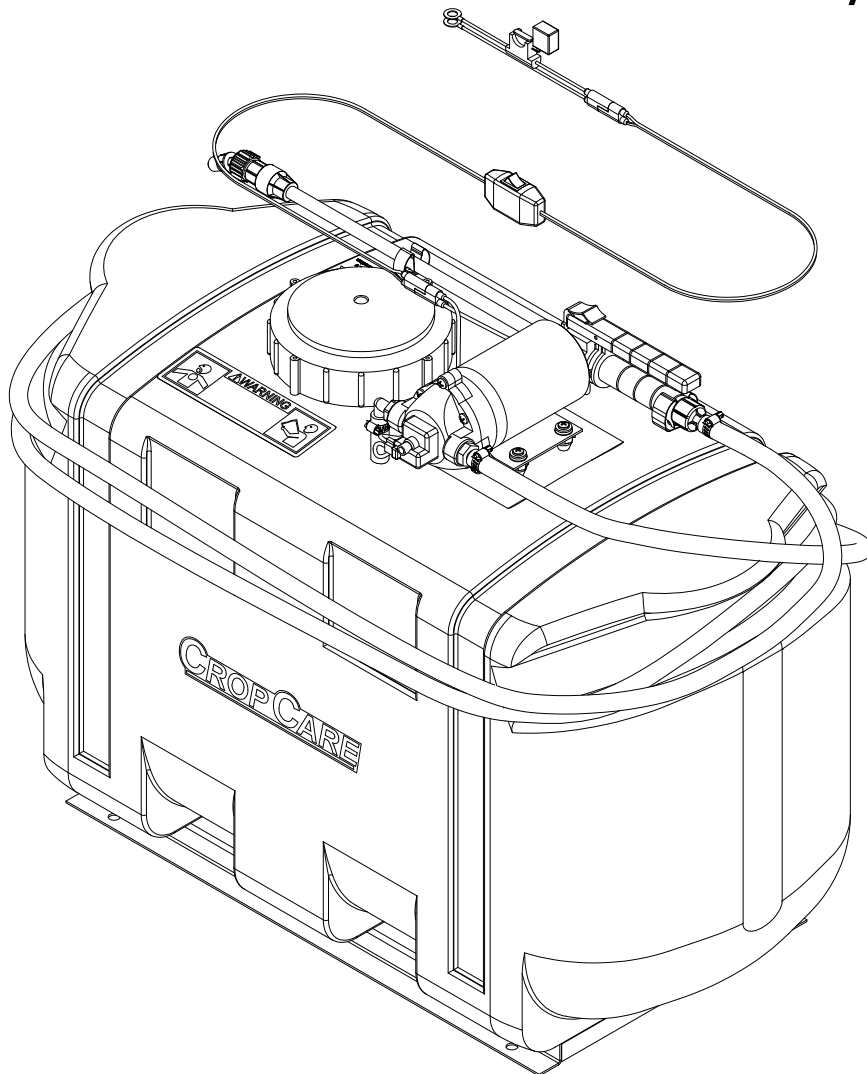

(717) 738-7365 | 50 Wood Corner Rd | Lititz PA 17543  
[www.CropCareEquipment.com](http://www.CropCareEquipment.com)  
A Paul B Zimmerman Inc. Company



CropCare® would like to thank you for choosing to purchase one of our Spot Sprayer models. We appreciate your business and want to fill all of your sprayer needs. We also desire to provide you with the technical support and needed parts that will allow you to continue spraying without disruption. For parts and service please contact your local CropCare® dealer.

# Table Of Contents

<b>Specifications</b> .....	3	<b>Maintenance Instructions</b> .....	8
<b>Before You Begin</b> .....	4	Routine Maintenance .....	8
<b>Safety Precautions</b> .....	4	Winterizing your Sprayer .....	8
General Guidelines.....	4	<b>Troubleshooting</b> .....	9
During Operation.....	5	<b>Breakdowns &amp; Parts Lists</b> .....	10
Following Operation.....	5	LG25 Breakdown.....	10
Pump Safety Precautions.....	5	LG25 Parts List.....	11
Before Operation .....	5	Decal List.....	11
<b>Mounting the Sprayer</b> .....	6	Shurflo Pump Breakdown.....	12
Base Unit.....	6	Shurflo Pump Parts List.....	12
Wiring Harness.....	6	<b>Accessories</b> .....	13
<b>Operating Instructions</b> .....	7	<b>CropCare® Limited Warranty</b> .....	14
Before and During Operation.....	7	<b>Contact Us</b> .....	15
Following Operation .....	7	Ordering Parts.....	15

# Specifications

**25 gallon Spot Sprayer**  
**Model #'s: LG25**

Tank capacity ..... 25 gal  
 Min power supply..... 12 volt / 10 amp  
 Wiring harness length..... 8'

**Pump:**  
 Type ..... Diaphragm pump  
 Manufacturer..... Shurflo®  
 Max pressure ..... 60 psi  
 Open flow rate..... 1.8 gpm

**Sprayer:**  
 Hose length ..... 15'

**Weight:**  
 Shipping weight..... 25 lbs

# Before You Begin



**Please read and understand this manual and its instructions and warnings completely before operating the sprayer.**

- **Be aware of all safety guidelines, warnings, and cautions including those of any piece of equipment that the sprayer may be mounted on.**
- **Read and understand the chemical manufacturer's labels, warnings, and instructions.**
- **Know and fulfill all state pesticide applicator license requirements.**
- **Familiarize yourself and other operators with the sprayer's components and how all parts are operated.**

## Safety Precautions



### General Guidelines

Every year many unnecessary accidents occur due to improper equipment handling and a disregard for safety precautions. You, the operator, can avoid accidents by observing the precautions listed in this section.

- The operator should be a responsible adult. Do not allow persons to operate this sprayer until they have displayed a thorough understanding of sprayer safety precautions and operational use!
- All operators must also fulfill state pesticide applicator license requirements!
- Never attempt to operate this sprayer when under the influence of alcohol or drugs.
- The best defense against accidents is a careful and responsible operator.
- A chemical warning decal and an owner's manual warning decal are located on the sprayer's tank. (Figure 1, Figure 2). Be aware of their location. Always replace any warning or safety decals that are not legible or are missing.
- When transporting the sprayer on public roads, always follow state and local regulations regarding safety and transportation requirements. Use the necessary lights and slow moving vehicle (SMV) emblems.
- If there is any portion of this manual that you do not fully understand, please contact your local CropCare® dealer.



Figure 1: Chemical Warning Decal (DEMT3980)



Figure 2: Owner's Manual Decal (DE39)

# Safety Precautions



## Before Operation

- Carefully study and understand this owner's manual.
- Read and follow chemical manufacturer's labels, warnings, and instructions! A material safety data sheet (MSDS) should be provided by the chemical manufacturer.
- To avoid injury from chemical hazards, wear the proper protective clothing. Each chemical manufacturer's clothing requirements are listed under the "Personal Protective Equipment (PPE) section in the chemical instructions.
- Do not wear loose-fitting clothing which may catch in moving parts.
- Never exceed the load rating for the piece of equipment the sprayer is mounted on.
- Give the sprayer a visual inspection for any worn parts, loose bolts, or other visible problems, and make the necessary repairs. See the maintenance section for instructions (page).
- Make sure the area is clear of any people or obstructions before using the sprayer.
- Have all operators practice operating the sprayer and its attachments, using clean water only, until all persons are completely capable of safe operation.



## During Operation

- Always be aware of bystanders, particularly children!
- No passengers are allowed on or in the the equipment the sprayer is mounted on.
- Keep hands and body parts clear of all moving parts.
- Never leave running equipment unattended!
- Allow for sprayer boom length when making turns.
- Be aware of dangerous terrain such as holes, slopes, drop-offs, banks, rocks, and hidden hazards.
- Operate the equipment and sprayer up and down slopes, not across.
- Remember that accidents can even happen to seasoned operators. Always take your time and follow all safety instructions.



## Following Operation

- Following operation, stop the equipment, set brakes, shut off engine, and remove ignition key.
- Park the sprayer on a hard level surface
- Do not permit children to play on or around sprayer.
- Store the sprayer away from human and livestock activity.



## Pump Safety Precautions

- Never pump flammable or explosive fluids such as gasoline, fuel oil, kerosene, etc.
- Note: The pump may be run dry for limited periods of time without resulting in damage.
- Always disconnect the power to the pump when working on the pump. Failure to do this could result in electrical shock.

# Mounting the Sprayer

The Spot Sprayer is designed to be mounted on the rack of an ATV, on a garden trailer, or any other utility vehicle. Mounting the sprayer correctly and securely will ensure consistent and safe spraying.

## Base Unit

1. Before installing your sprayer, make sure that the sprayer unit does not exceed the equipment manufacturer's load rating. The sprayer unit could weigh up to 210 lbs when filled with 25 gallons of water.
2. The sprayer tank is mounted on a powder-coated steel frame (a) with four pre-drilled holes. For optimal stability mount the sprayer with bolts (b) using the pre-drilled holes in the sprayer frame (Figure 3).
3. For some temporary situations it may be more convenient to strap the sprayer to your equipment (a) with heavy-duty straps (b) (Figure 4). If you choose to strap the sprayer down ensure that it is fastened securely.

**Note:** If you are permanently mounting the sprayer in an outdoors location, it is important that you cover the pump to protect it from the elements.

## Wiring Harness

1. The pump wiring harness (a) has a 2-pronged plug. This wiring harness needs to be connected to the switch wiring harness (b) which includes the control switch. Make sure the wire colors match (Figure 5).
2. The switch wiring harness (b) needs to be connected to the battery wire harness (c) which includes the 15 amp fuse (d). Make sure the wire colors match (Figure 5).
3. The battery wire harness needs to be connected to a 12 volt DC power source. Connect the red wire to a positive power source either to the vehicle's battery terminal or at a power access point with at least 10 amp capability. The black wire needs to be connected to a good ground source or to the negative terminal of the battery.

**Note:** The end of the wiring harness with the ring terminals (d) is detachable and can be left attached to the battery for convenience purposes.

4. Ensure that the power source is adequate, since an inadequate power source could cause numerous problems with your sprayer. If you are using a power access point, ensure that it has at least 10 amp capability.

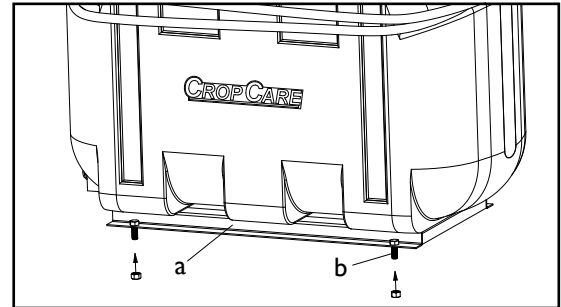

Figure 3: Mounting the sprayer with bolts

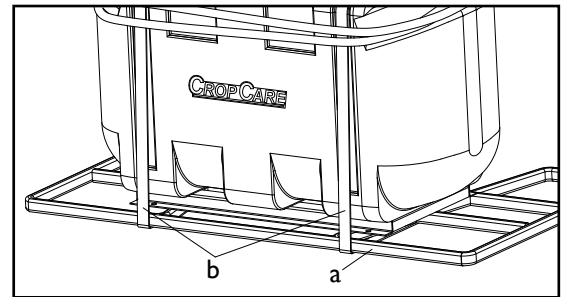

Figure 4: Mounting the sprayer with straps

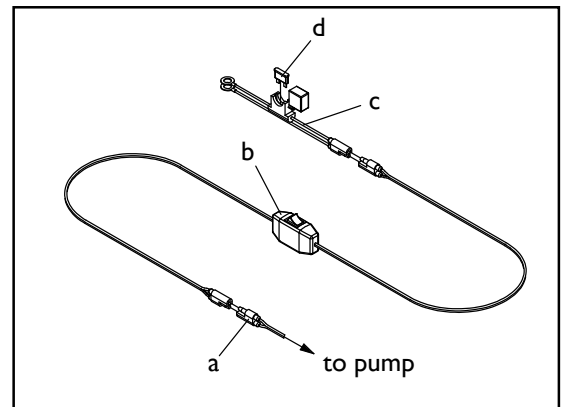

Figure 5: Wiring Harness

5. You now need to place the switch in a location where it is easily accessible for operation. Secure it so that it cannot fall or become entangled and cause damage.

**Note:** The end of the wiring harness with the ring terminals (d) is detachable and can be left attached to the battery for convenience purposes.

# Operating Instructions

Before operating the sprayer, it is important that you read this entire manual and know all safety precautions. Always take your time and be alert when operating the sprayer in order to avoid an accident.

## Before and During Operation

1. Before operation it is important to give the sprayer unit a thorough inspection, which covers the hoses, wiring harness, and other sprayer components. Ensure that the suction strainer and the tank are rinsed out.
2. Before using any chemical or product ensure that it is not a petroleum-based product or a non-compatible chemical for the pump.
3. Fill the sprayer tank with the proper amount of water and chemicals as instructed by the chemical manufacturer.
4. Connect the wiring harness to an approved power source as directed in the Mounting the Sprayer section (Page 6). Turn the control switch to the ON position and allow the pump to run until it reaches its maximum pressure. The pump will automatically turn off when its maximum pressure is reached. The pump does not need to be manually turned off with the control switch.
5. When you are ready to spray, point the gun in the desired direction and squeeze the trigger on the spray gun. The pump will automatically start when the spray gun is engaged.

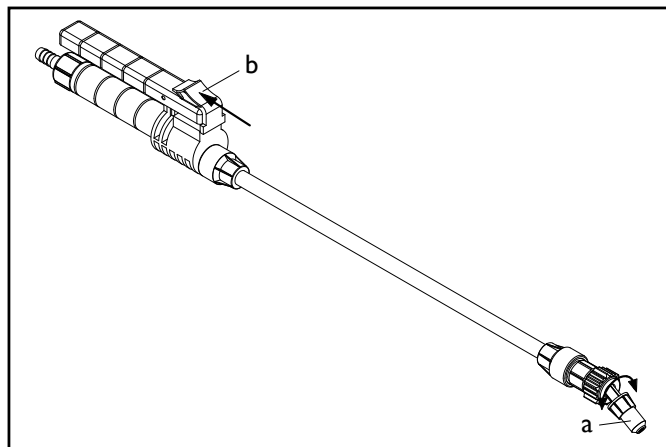

Figure 6: Spray gun

6. The spray gun's liquid flow can be adjusted by turning the spray tip (a) at the end of the spray gun wand. The spray gun's trigger can also be locked in the "on" position by sliding the plastic tab (b) on the top of the trigger towards yourself (Figure 6).

Note: Using a petroleum-based product or a non-compatible chemical will void the manufacturer's warranty. Contact an authorized CropCare® dealer if you are unsure as to whether or not a chemical or substance is acceptable for the pump.

## Following Operation

1. Thoroughly rinsing the sprayer of any chemical residue is an important activity. It is recommended to fill the tank with fresh water and engage the spray gun until the system is entirely free of chemical residue. It is important not to rinse the sprayer in an area where humans, animals, or sensitive plants could come in contact with chemical residue.
2. Store the sprayer in a location where it will be away from human or animal activity. Do not allow children to play on or near the sprayer.

# Maintenance Instructions

## Routine Maintenance

It is very important to perform routine maintenance on your sprayer before and after each use. Good maintenance practices will help to guard against any unnecessary sprayer breakdowns or accidents.

1. It is recommended to perform a visual and physical inspection for any worn parts, loose bolts, or other visible problems. Make all necessary repairs before spraying. Contact an authorized CropCare® dealer for instructions on ordering parts and for technical help.
2. The suction strainer (ref # 1, page 10) is located on the end of suction hose (inside the tank) and should be inspected and rinsed off on a regular basis.
3. After each use it is important to rinse the pump and all components by running water through the system. Fill the tank with a sufficient amount of fresh water and engage the spray gun. Rinsing the pump with fresh water will greatly improve the life of the pump.
4. Always follow all pump safety precautions and warnings (Page 5). Following these guidelines will help to ensure many years of smooth and trouble-free spraying.

## Winterizing your Sprayer

It is essential that you winterize your sprayer to avoid damage and to allow for optimal performance. The winterization process should be undertaken before freezing conditions and/or after each season of use. **Failure to winterize your sprayer will void the manufacturer's warranty.**

1. Verify that the tank is rinsed out and empty. Pour a 1/2 gallon of RV nontoxic antifreeze into the tank. It is not recommended to use engine antifreeze. Engine antifreeze can be harmful to humans, animals, crops, and the environment.
2. Engage the pump and spray with the spray gun for several minutes. Make sure that the antifreeze has been pumped through the entire system.
3. Store the sprayer in a dry location away from the elements.
4. Before spraying in the spring it is recommended to flush the sprayer with fresh water to cleanse it of the antifreeze and any other buildup. It would also be beneficial to do a thorough inspection of all sprayer components before spraying.



# Troubleshooting

As you use your Spot Sprayer, it is possible that you will encounter minor problems that can be easily fixed. The following problems and respective causes and solutions should cover most of the potential problems that you may face. If you are having problems please attempt to use this troubleshooting section to solve the problem. If you are unable to fix the problem please contact an authorized CropCare® dealer for service.

Problems/Symptoms	Possible Causes	Solutions
<b>Low Rate of Flow</b>	Suction Strainer is partially clogged	Remove the suction strainer and rinse
	Pump valves are damaged/bad	Replace the valves or contact an authorized CropCare® dealer for service and/or repairs
	Low voltage	Use a power source rated at 10 amps and 12 volts
<b>Pump Will Not Prime</b>	Suction line is clogged	Inspect the suction line for debris
	Suction strainer is clogged	Remove the suction strainer and rinse
	Pump is damaged from chemicals not being properly rinsed out	See an authorized CropCare® dealer for service and/or pump repairs
<b>Pump Will Not Run</b>	Fuse is blown	Replace the fuse on the wiring harness
	Incorrect voltage	Use a power source rated at 10 amps and 12 volts
	Pump pressure switch is malfunctioning	Replace the pressure switch or contact an authorized CropCare® dealer for repairs
<b>No Spray Flow</b>	Spray tip is clogged	Remove the spray tip and rinse out
	Suction strainer is clogged	Remove the suction strainer and rinse

# Breakdowns & Parts Lists

## LG25 Breakdown

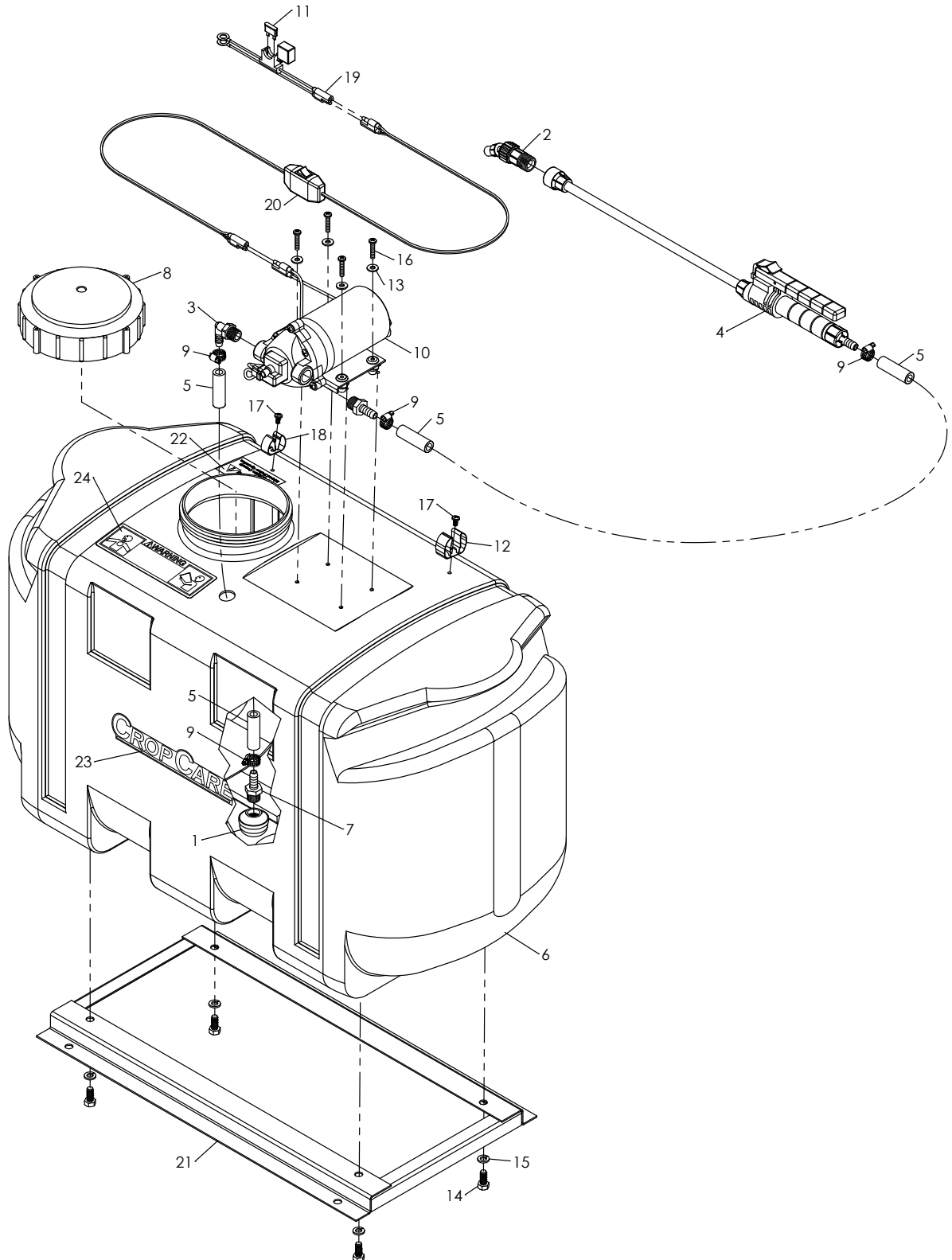

# Breakdowns & Parts Lists

## LG25 Parts List

Ref #	Qty.	Part Number	Description
1	1	10416D	Suction strainer, 40 mesh
2	1	38720PPBX18	* Adjustable spray nozzle, #18
3	1	3EL3838	3/8" MPT x 3/8" barb poly elbow
4	1	5080015PP406	Spray gun, 3/8" hose barb <b>(Includes ref # 2)</b>
5	N/A	6106	Hose, 1/2"
6	1	10956	25 gal. yellow lawn and garden poly tank <b>(Includes ref # 8)</b>
7	2	3A3838	3/8" MP x 3/8" barb adapter
8	1	60323	* 5" Lid
9	4	62604	stainless hose clamp
10	1	8000-543-936	** Shurflo pump, 12 volt, 1.4 gpm
11	1	ATC-15	* ATC fuse, 15amp
12	1	C13201	Large grip clamp
13	4	FW14S	Flat washer, 1/4", stainless
14	4	H5C516*34	hex head bolt, 5/16-18 x 3/4" grade 5
15	4	LW516	lock washer, 5/16"
16	4	MR1024*1S	Machine screw, 10-24 x 1", stainless
17	2	MR1024*38s	Machine screw, 10-24 x 3/8", stainless
18	1	NI89472	Small grip clip
19	1	SPT-BCG-1215A-16G	Battery connector with fuse <b>(Includes ref # 11)</b>
20	1	SPT-SWH-9615A16G	8' wire harness with switch
21	1	T232	Frame

\* Individual part is included in a complete assembly

\*\* Pump breakdown is listed on page 12

## Decal List

Ref #	Qty.	Part Number	Description
22	1	DE39	Read owner's manual warning decal
23	1	DE46	Decal, "CROP CARE"
24	1	DEMT3980	Chemical warning decal

# Breakdowns & Parts Lists

## Shurflo® Pump Breakdown

Model: 8000-543-936

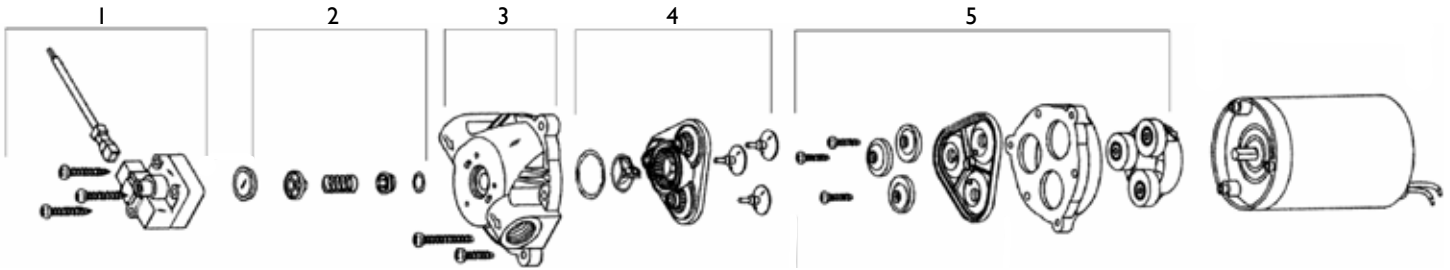

## Shurflo® Pump Parts List

Ref #	Qty.	Part Number	Description
1	1	9437505	Switch kit, viton, 60 psi
2	1	9437405	Check valve kit
3	1	9437900	Upper housing kit
4	1	9439005	Valve kit, viton
5	1	9438532	Diaphragm and drive kit, santoprene

# Accessories



## 3/8" Vinyl Reinforced Hose

Part Number: 6106

Additional hose comes in handy for reaching those hard-to-get-to areas. This durable hose can be cut to length and is available in additional sizes.

---



## Adjustable Brass Spray Tip

Part Number: 5500X18

Upgrade your spray gun with this durable brass spray tip. This spray tip is adjustable and will increase the performance of your spray gun.

---



## 10' Wiring Harness Extension

Part Number: 9428

Need an additional length of wire? A 10' wiring harness extension simply plugs into your existing wiring harness giving you the length you need.

---



## TriggerJet® Spray Gun

Part Number: 22670PP1514

Increase your spraying performance by replacing your existing spray gun with a TriggerJet spray gun. This spray gun features a 15" wand can be repaired with replacement parts

# CropCare<sup>®</sup> Limited Warranty

## Spot Sprayer: Model LG25

## Warranty Coverage

CropCare<sup>®</sup> hereby provides a Limited One (1) Year Warranty on Spot Sprayers, manufactured by CropCare<sup>®</sup>. Spot Sprayers manufactured by CropCare<sup>®</sup> are warranted against any manufacturer's defects in any of the sprayer's components in the 12 months following the original date of purchase.

Defective components will be repaired or replaced at the discretion of the manufacturer. It is the responsibility of the purchaser to return warranted components to the manufacturer. This warranty is limited to the repair or replacement of sprayer components only. CropCare<sup>®</sup> is not to be held liable for incidental or consequential damages of any kind. This warranty covers the purchaser of this Spot Sprayer and any other owners who own it during the one year warranty period.

To retain the warranty, the sprayer must be operated and maintained as ascribed by its owner's manual. For warranty service, please have a copy of the purchase invoice available.

## Warranty Is Void if:

1. The sprayer has been subjected to, in the opinion of CropCare<sup>®</sup>, negligent handling, misuse, an accident or if the instructions in the owner's manual were not completely followed.
2. The sprayer's components have been altered in any manner or repairs have taken place with unapproved parts.
3. The sprayer and its components were subject to freezing or freezing conditions. The sprayer must have been winterized as per the maintenance instructions to retain the warranty.
4. A non-compatible chemical was used and/or if the sprayer operator failed to rinse all chemical residue out of the sprayer's components after use.
5. A petroleum-based, oil-based, or flammable product was used and caused damage to the pump, tank, hoses, or any other component.

## Getting Warranty Service

All Spot Sprayer warranty claims must be made through an authorized CropCare<sup>®</sup> dealer. All warranty claims must be submitted with an invoice or a proof of purchase that denotes the purchase date and place of purchase. If you have any questions or comments concerning this warranty, please contact an authorized CropCare<sup>®</sup> dealer.

# Contact Us

We desire to give you continuing service in the best manner possible. This includes listening to your comments, suggestions, and problems. We will do our best to answer all questions thoroughly and in a timely manner. We have trained customer service specialists who are more than willing to listen to any questions or problems and help you to find a feasible solution.

## Ordering Parts

We have a fully-stocked parts department that will be able to meet all of your parts needs. Our trained customer service specialists will ensure that all purchases are processed smoothly and shipped in a timely manner. We regularly ship our parts and products on the same business day and we are willing to work with you to find the best shipping solution. We also offer priority shipping to reduce your downtime and keep your CropCare® equipment on the job.

# **CROP CARE**

### **PBZ LLC**

A Paul B Zimmerman Inc. Company

50 Wood corner Road

Lititz PA 17543

(717) 738-7365

Fax (717) 738-8061

[www.CropCareEquipment.com](http://www.CropCareEquipment.com)

