



Owner's Manual

High Pressure Produce Sprayer
300 Gallon

Model # VGX300T

PBZ LLC | 295 Wood Corner Rd | Lititz PA 17543
www.CropCareEquipment.com | (717) 738-7365
A Paul B Zimmerman Inc. Company

Form: VGX300TOM
Rev. Date 03/14

CropCare® would like to thank you for choosing to purchase one of our trailer sprayer models. We appreciate your business and want to fill all of your sprayer needs. We also desire to provide you with the technical support and needed parts that will allow you to continue spraying without disruption. For parts and service please contact your local CropCare® dealer.

Table Of Contents

Before You Begin.....	3	During Operation	12
Safety Precautions.....	4	Operating the Rinse System	13
General Guidelines.....	4	Following Operation	13
Chemical Warnings	4	Maintenance Instructions	13
Towing the Sprayer	5	Routine Maintenance.....	13
Before Operation	5	Pump Maintenance	15
During Operation	6	Winterizing your Sprayer	15
Following Operation	6	CropCare® Limited Warranty.....	16
Pump Safety Precautions.....	7	Contact Us.....	17
Calibrating the Sprayer.....	7	Ordering Parts.....	17
Determining the Speed.....	7		
Calculating the GPM and using Calibration chart	8		
Adjusting the Sprayer Pressure	8		
Calibration Chart.....	9		
Alternative Boom Spacing formulas.....	10		
Notes	10		
Operating Instructions	11		
Before Spraying.....	11		
Preparing the Sprayer	12		

Before You Begin



Please read and understand this manual and its instructions and warnings completely before operating the sprayer.

- Be aware of all safety guidelines, warnings, and cautions including those of the tractor manufacturer.
- Read and understand the chemical manufacturer's labels, warnings, and instructions.
- Know and fulfill all state pesticide applicator license requirements.
- Familiarize yourself and other operators with the sprayer's components and how all parts are operated.

Safety Precautions



General Guidelines

Every year many unnecessary accidents occur due to improper equipment handling and a disregard for safety precautions. You, the operator, can avoid accidents by observing the precautions in this section.

- The best defense against accidents is a careful and responsible operator.
- The operator should be a responsible adult. Do not allow persons to operate this sprayer until they have displayed a thorough understanding of sprayer safety precautions and operational use!
- Never attempt to operate this sprayer when under the influence of alcohol or drugs.
- Practicing safe PTO operation is immensely important! Failure to keep body parts or clothing clear of the sprayer's PTO drive shaft could result in serious injury or death. CropCare® assumes no liability for any possible injury.
- Be aware of the PTO warning decal on the PTO drive shaft (Figure 1).
- Never step over, or work near the PTO drive shaft during operation.
- Always replace any missing or damaged PTO shields!



Figure 1: PTO warning decal

- If there is any portion of this manual that you do not fully understand, please contact an authorized CropCare® dealer.



Chemical Warnings

- All operators must also fulfill state pesticide applicator license requirements!
- Be aware of the chemical warning decal on the sprayer tank (Figure 2).
- Read and follow chemical manufacturer's labels, warnings, and instructions! A material safety data sheet (MSDS) should be provided by the chemical manufacturer.
- To avoid injury from chemical hazards, wear the proper protective clothing. Each chemical manufacturer's clothing requirements are listed under the "Personal Protective Equipment (PPE)" section in the chemical instructions.
- If the sprayer is equipped with a rinse system, clean water from the rinse tank can be dispensed through the drum valve on the side of the tank to cleanse yourself of harmful chemical contact.

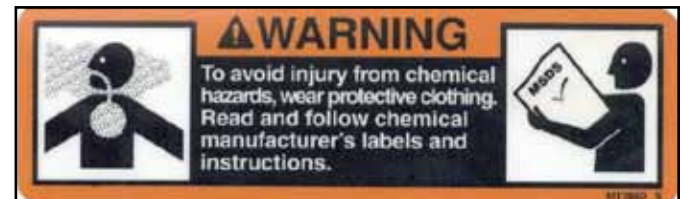

Figure 2: Chemical Warning Decal (DEMT3980)



Figure 3: Fresh Water Only decal (DE21)

- Never put chemicals or any substances other than clean fresh water in the rinse tank. Be aware of the fresh water warning decal (Figure 3).

Safety Precautions



Towing the Sprayer

- When transporting the sprayer on public roads, always follow state and local regulations regarding safety and transportation requirements. Use the necessary lights and slow moving vehicle (SMV) emblems.
- Never exceed your tractor, or alternative vehicle's load and/or tow ratings. The TR300S weighs approximately 2500 lbs empty, and 5000 lbs with 300 gallons of water .
- When transporting the sprayer, the sprayer's boom must be in the fully closed position and secured. The boom is secured by closing the ball valve located on the hydraulic folding cylinder (Figure 4).
- The sprayer cannot exceed speeds of 25 mph. Exceeding 25 mph could harm the tires and/or increase the possibility of the sprayer overturning. Exceeding 25 mph will void the manufacturer's warranty.



Figure4:Hydraulicvalvewarningdecal(DE25)

- Be aware of the hydraulic valve warning decal (Figure 4).
- The left sprayer tire contains 13 gallons of non-toxic, RV antifreeze for counter weight for the boom. When changing tires, always fill the left tire with non-toxic, RV antifreeze, failure to do so will void the manufacturer's warranty.



Before Operation

- Be aware of the location of all the safety and warning decals. Always replace any decals that are illegible or are missing.
- Carefully study and understand this owner's manual.
- Be aware of the owner's manual decal (Figure 5).
- Before adding chemicals, have all operators practice operating the sprayer (clean water only) and its attachments until all operators are completely capable of safe operation.
- Do not wear loose-fitting clothing which may catch in moving parts.
- Give the sprayer a visual inspection for any worn parts, loose bolts, or other visible problems, and make the necessary repairs.
- Never check for hydraulic hose leaks with your hands. If oil penetrate's the skin and enters the bloodstream, the results could be fatal. If there is any visible damage to the hoses, replace them immediately.

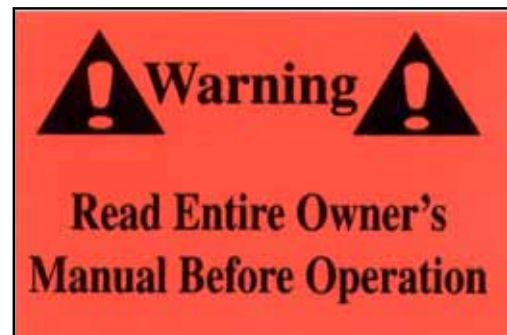

Figure5Owner'sManualDecal(DE39)

- All sprayer maintenance should be performed with the sprayer unhooked from the tractor and clean of any harmful chemicals.
- Make sure the area is clear of any people or obstructions before using the sprayer.

Safety Precautions



During Operation

- Always be aware of bystanders, particularly children! Always look before moving the sprayer or engaging the PTO. Bystanders should never be allowed near the sprayer during operation.
- No passengers are allowed on or in the tractor or sprayer at any time.
- The sprayer's hydraulic boom, if improperly operated, can be very dangerous to the operator and/or bystanders. Do not allow anyone near the boom during operation or anytime the hydraulic system is engaged.
- Be aware of the boom's moving parts and the portions of the boom where the risk of pinching is high. It is also important to remember that the boom extends and swings in a fast progression. When extending the boom be aware of any obstructions that could damage the boom.
- Be aware of all the safety and warning decals on the boom (Figures 6-9).
- If the boom's movement is too fast or jolting, the hydraulic flow on most tractors can be adjusted. Proper flow adjustment can further increase the safety of the sprayer.
- Do not operate the rinse system (if applicable) at more than half throttle on the tractor. Excessive pressure could diminish performance and cause mechanical damage to the sprayer.
- Keep hands and body parts clear of all moving parts, especially the tractor PTO.
- Be aware of dangerous terrain such as holes, slopes, drop-offs, banks, rocks, and hidden hazards. Operate the tractor and sprayer up and down slopes, not across.
- When operating on inclines, it is especially important that your tractor is equipped with Roll Over Protection System (ROPS).



Figure 6 Pinch point decal (DE23)



Figure 7 Swinging boom warning decal (DE26)



Figure 8 Moving parts warning decal (DE24)

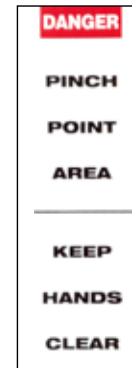

Figure 9 Pinch point decal (DE22)

- Allow for sprayer boom length when making turns.
- Never leave running equipment unattended!
- Remember that accidents can even happen to seasoned operators. Always take your time and follow all safety instructions.



Following Operation

- Following operation, stop the tractor unit, set the brakes, disengage PTO shaft, shut off the engine, and remove the ignition key.
- Completely rinse the entire sprayer and all of its components of all chemical residue after every use.
- Dispose of rinsate in accordance with chemical application guidelines.
- Park the sprayer on a hard level surface, away from all human and livestock activity
- Do not permit children to play on or around sprayer.

Safety Precautions



Pump Safety Precautions

- Never operate the pump at pressures over 290 psi. Operating the pump at pressures over 290 psi can cause damage to the pump and the controls, or cause personal injury. Operating the pump at pressures over 290 psi will void the manufacturer's warranty.
- Please note: Shutting off the boom sections during operation will cause a spike in pump pressure. The recommended maximum operating pressure is 250 psi.
- Never pump flammable or explosive fluids such as gasoline, fuel oil, kerosene, etc.
- Never run pump faster than, or above, the maximum recommended speed and pressure (540 rpm, 290 psi).
- Never pump liquids at temperatures higher than the recommended maximum temperature (140°F / 60°C). Do not exceed this temperature.
- Before servicing your pump, disconnect the power, release all pressure, and drain all liquids.

Calibrating the Sprayer

When spraying with the boom, the sprayer must be calibrated to ensure proper spray coverage and to combat over-application or under-application. Before calibrating the sprayer it is important to familiarize yourself with the operating instructions (page 11). The calibration process is simplified when broken down into the following three steps:

1. Determine the speed of the tractor.
2. Determine the nozzle size and use the calibration chart to find the correct pressure setting.
3. Set the pressure accordingly using the relief valve on the manual controls, or the pressure control toggle switch on the electric controls.

Note: All calibration must be done with clean water only!

1. Determining the Speed

It is important to determine what speed the tractor will be traveling at while spraying. While some tractors have speedometers, it is still recommended that speed is calculated for all tractors for accuracy purposes. To determine the speed follow these steps:

1. Measure a 200 foot or 300 foot distance on a field or a surface similar to where you will be spraying.
2. Drive the tractor and sprayer (tank half-full is optimal) across the measured distance at a constant rate of speed. There should be no changes in speed while you are measuring the time. This should be a comfortable speed for spraying.
3. Have someone, with a stopwatch, measure the amount of time (in seconds) it takes to travel the measured distance.
4. When measuring the time it takes to travel the measured distance, be sure that the tractor is traveling at the required speed before crossing the starting point of the measured distance. Also be sure that the tractor travels at a constant rate of speed and does not slow down until it has traveled the full measured distance.
5. Your speed can be found by entering your data into the equation (page 8) or by consulting the table (page 8).

Calibrating the Sprayer

1. Determining the Speed ...continued

Speed in MPH	Time required (seconds) to travel a distance of:	
	200 feet	300 feet
1.0	136	205
1.5	91	136
2.0	68	102
2.5	55	82
3.0	45	68
3.5	39	58
4.0	34	51
4.5	30	45
5.0	27	41
5.5	25	37
6.0	23	34
6.5	21	31
7.0	19	29

$$\text{Speed (mph)} = (\text{Distance (ft)} \times 60) \div (\text{Time (seconds)} \times 88)$$

Note: When calculating tractor speed be sure to select a gear that allows the tractor to operate between 75%-100% of the tractor's RPM range. This will allow the pump to operate at full volume. Selecting a higher gear will not allow the pump to work efficiently.

Note: It is helpful for future references to record the exact RPM and gear used to find your speed.

2. Calculating the GPM and using Calibration Chart

The spray nozzles on your sprayer are color-coded and match up with the calibration chart. After the nozzle size has been determined, you need to look at the calibration chart. Using the tractor speed, nozzle size, and desired gallons per acre (GPA), find the pressure (psi) necessary to achieve the desired GPA.

Example: Assume you have found your tractor speed to be 3 MPH, your nozzles are blue (TXA8002VK), and you want to spray 60 GPA. Upon looking at the chart, you will find that you should set the sprayer's pressure at about 220 psi in order to apply 60 GPA.

3. Adjusting the Sprayer Pressure

You have found the correct pressure setting, but must now adjust the sprayer to that pressure setting. Before you adjust the sprayer's pressure, it is important to set the tractor's RPM at the same RPM that was used to find the tractor's speed. If your sprayer is equipped with manual controls, the pressure is adjusted by turning the pressure knob on the control. If your sprayer is equipped with electric controls, the pressure is adjusted by moving the pressure control toggle switch.

Note: Due to normal wear, Teejet® recommends that you replace your sprayer nozzles after every spraying season. Nozzle replacement will ensure accurate spraying performance.

Calibrating the Sprayer

Calibration Chart

Please note: Flow rates are calculated using water. This table is only relevant for booms with 15" nozzle spacing. If your boom has an alternative nozzle spacing measurement, reference page 11 for the formula to calculate the relevant gallons per acre (GPA) figures.

Tip Size	PSI	GPM of one nozzle	Gallons per Acre (15" spacing)				
			3 MPH	3.5 MPH	4 MPH	5 MPH	6 MPH
6.65TXA800050VK (lavender)	40	.050	6.60	5.66	4.95	3.96	3.30
	60	.060	7.92	6.79	5.94	4.75	3.96
	80	.068	8.98	7.69	6.73	5.39	4.49
	100	.075	9.90	8.49	7.43	5.94	4.95
	120	.081	10.69	9.16	8.02	6.42	5.35
	140	.086	11.35	9.73	8.51	6.81	5.68
	160	.092	12.14	10.41	9.11	7.29	6.07
	180	.096	12.67	10.86	9.50	7.60	6.34
	200	.101	13.33	11.43	10.00	8.00	6.67
	220	.105	13.86	11.88	10.40	8.32	6.93
	240	.109	14.39	12.33	10.79	8.63	7.19
	260	.113	14.92	12.79	11.19	8.95	7.46
280	.117	15.44	13.24	11.58	9.27	7.72	
TXA800067VK (brown)	40	.067	8.84	7.58	6.63	5.31	4.42
	60	.080	10.56	9.05	7.92	6.34	5.28
	80	.091	12.01	10.30	9.01	7.21	6.01
	100	.101	13.33	11.43	10.00	8.00	6.67
	120	.110	14.52	12.45	10.89	8.71	7.26
	140	.118	15.58	13.35	11.68	9.35	7.79
	160	.125	16.50	14.14	12.38	9.90	8.25
	180	.132	17.42	14.93	13.07	10.45	8.71
	200	.139	18.35	15.73	13.76	11.01	9.17
	220	.145	19.14	16.41	14.36	11.48	9.57
	240	.151	19.93	17.08	14.95	11.96	9.97
	260	.157	20.72	17.76	15.54	12.43	10.36
280	.162	21.38	18.33	16.04	12.83	10.69	
TXA8001VK (orange)	40	.100	13.20	11.31	9.90	7.92	6.60
	60	.120	15.84	13.58	11.88	9.50	7.92
	80	.137	18.08	15.50	13.56	10.85	9.04
	100	.152	20.06	17.20	15.05	12.04	10.03
	120	.165	21.78	18.67	16.34	13.07	10.89
	140	.177	23.36	20.03	17.52	14.02	11.68
	160	.188	24.82	21.27	18.61	14.89	12.41
	180	.199	26.27	22.52	19.70	15.76	13.13
	200	.208	27.46	23.53	20.59	16.47	13.73
	220	.218	28.78	24.67	21.58	17.27	14.39
	240	.226	29.83	25.57	22.37	17.90	14.92
	260	.235	31.02	26.59	23.27	18.61	15.51
280	.243	32.08	27.49	24.06	19.25	16.04	

Please Note: Flow rates are calculated using fresh water. Always remember to double check application rates.

Calibrating the Sprayer

Calibration Chart ... continued

Tip Size	PSI	GPM of one nozzle	Gallons per Acre (15" spacing)				
			3 MPH	3.5 MPH	4 MPH	5 MPH	6 MPH
TXA80015VK (green)	40	.150	19.80	16.97	14.85	11.88	9.90
	60	.182	24.02	20.59	18.02	14.41	12.01
	80	.209	27.59	23.65	20.69	16.55	13.79
	100	.232	30.62	26.25	22.97	18.37	15.31
	120	.254	33.53	28.74	25.15	20.12	16.76
	140	.273	36.04	30.89	27.03	21.62	18.02
	160	.291	38.41	32.92	28.81	23.05	19.21
	180	.308	40.66	34.85	30.49	24.39	20.33
	200	.324	42.77	36.66	32.08	25.66	21.38
	220	.339	44.75	38.36	33.56	26.85	22.37
	240	.353	46.60	39.94	34.95	27.96	23.30
	260	.367	48.44	41.52	36.33	29.07	24.22
280	.380	50.16	42.99	37.62	30.10	25.08	
TXA8002VK (yellow)	40	.200	26.40	22.63	19.80	15.84	13.20
	60	.243	32.08	27.49	24.06	19.25	16.04
	80	.279	36.83	31.57	27.62	22.10	18.41
	100	.310	40.92	35.07	30.69	24.55	20.46
	120	.338	44.62	38.24	33.46	26.77	22.31
	140	.364	48.05	41.18	36.04	28.83	24.02
	160	.388	51.22	43.90	38.41	30.73	25.61
	180	.410	54.12	46.39	40.59	32.47	27.06
	200	.432	57.02	48.88	42.77	34.21	28.51
	220	.452	59.66	51.14	44.75	35.80	29.83
	240	.471	62.17	53.29	46.63	37.30	31.09
	260	.489	64.55	55.33	48.41	38.73	32.27
280	.507	66.92	57.36	50.19	40.15	33.46	
TXA8003VK (blue)	40	.300	39.60	33.94	29.70	23.76	19.80
	60	.367	48.44	41.52	36.33	29.07	24.22
	80	.423	55.84	47.86	41.88	33.50	27.92
	100	.473	62.44	53.52	46.83	37.46	31.22
	120	.517	68.24	58.49	51.18	40.95	34.12
	140	.558	73.66	63.13	55.24	44.19	36.83
	160	.597	78.80	67.55	59.10	47.28	39.40
	180	.633	83.56	71.62	62.67	50.13	41.78
	200	.667	88.04	75.47	66.03	52.83	44.02
	220	.699	92.27	79.09	69.20	55.36	46.13
	240	.733	96.76	82.93	72.57	58.05	48.38
	260	.759	100.19	85.88	75.14	60.11	50.09
280	.788	104.02	89.16	78.01	62.41	52.01	

Please Note: Flow rates are calculated using fresh water. Always remember to double check application rates.

Calibrating the Sprayer

Calibration Chart ... continued

Tip Size	PSI	GPM of one nozzle	Gallons per Acre (15" spacing)				
			3 MPH	3.5 MPH	4 MPH	5 MPH	6 MPH
TXA8004VK (red)	40	.400	52.80	45.26	39.60	31.68	26.40
	60	.489	64.55	55.33	48.41	38.73	32.27
	80	.564	74.45	63.81	55.84	44.67	37.22
	100	.630	83.16	71.28	62.37	49.90	41.58
	120	.690	91.08	78.07	68.31	54.65	45.54
	140	.745	98.34	84.29	73.76	59.00	49.17
	160	.796	105.07	90.06	78.80	63.04	52.54
	180	.843	111.28	95.38	83.46	66.77	55.64
	200	.889	117.35	100.58	88.01	70.41	58.67
	220	.932	123.02	105.45	92.27	73.81	61.51
	240	.973	128.44	110.09	96.33	77.06	64.22
	260	1.01	133.32	114.27	99.99	79.99	66.66
	280	1.05	138.60	118.80	103.95	83.16	69.30

Please Note: Flow rates are calculated using fresh water. Always remember to double check application rates.

Alternative Boom Spacing Formulas

If your sprayer has a nozzle spacing measurement that is different from the 15" nozzle spacing used on the chart on page 9, you can use the following multipliers to find Gallons per Acre (GPA) figures that correspond to your sprayer. Relevant GPA figures can be simply found by using the GPA figures found on the calibration chart and multiplying them by the correct multiplier for your nozzle spacing.

16" Nozzle Spacing:
Multiplier: .9375

17" Nozzle Spacing:
Multiplier: .8824

18" Nozzle Spacing:
Multiplier: .8333

Example: Assume you have found your tractor speed to be 3 MPH, your nozzles are spaced 17" apart, your nozzles are blue (TX-A8003VK). Upon looking at the calibration chart, you find that at a pressure of 120 PSI with 15" spacing the GPA is 68.24. To find your sprayer's GPA, multiply the GPA for 15" spacing by the 17" spacing multiplier (.8824) and you will find that your sprayer's GPA is 60.21 ($68.24 \times .8824 = 60.21$).

Operating Instructions

Before operating the sprayer, it is important that you read this entire manual and know all safety precautions. Always take your time and be alert when operating your sprayer. This will allow you to safely spray without accident or interruption.

Before Spraying

1. To avoid injury from chemical hazards, wear the proper protective clothing. Each chemical manufacturer's clothing requirements are listed under the "Personal Protective Equipment (PPE) section in the chemical's instructions.
2. Hook the sprayer up to your tractor with a high stress hitch pin. Contact your local CropCare® dealer to order an appropriate hitch pin.
3. If your sprayer is equipped with a hydraulic boom, connect the four hydraulic hoses to the tractor's hydraulic ports. The hydraulic hoses come in pairs for height adjustment and for leveling and folding. The pairs must be connected together for proper operation.
4. Connect the sprayer's PTO drive shaft to the tractor's PTO shaft. The tractor's PTO shaft must be a 540 RPM shaft. Ensure the sprayer's PTO shield is completely intact and has no damage.
5. It is very important to adjust your tractor's draw bar length to the correct length. The distance from the hitch point (hitch pin) to the pump U-joint should be equal to the distance from the hitch pin to the PTO U-joint (Figure 10). This will reduce wear on the U-joints and pump.
6. Prepare the sprayer controls for operation. If you sprayer is equipped with electric controls, mount the control box on the tractor and follow all of the manufacturer's installation instructions to ensure proper performance.
7. Fill the sprayer's tank with clean fresh water in order to test the sprayer. Testing the sprayer before operation

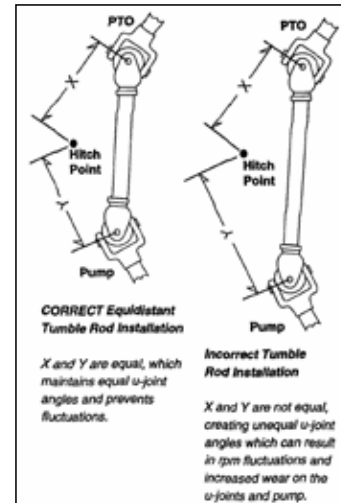

Figure 10. Correct hitch point placement

will give you a chance to familiarize yourself with all of the components and to test for any leaks or problems.

8. Engage the sprayer's pump and set the pressure using the sprayer's controls. Practice operating the sprayer's boom using the tractor's hydraulic controls. See the During Operation section (page 12) for more operational instructions. Inspect the sprayer for any leaks or problems. If you have any questions or concerns please contact your local CropCare® dealer.
9. Calibrate the sprayer using the preceding calibration instructions (page 7) and calibration chart. This will determine what pressure to spray at and what nozzles to use in order to achieve the desired GPA.

Preparing the Sprayer

1. You may now fill the tank with the amount of water and chemicals recommended by the chemical manufacturer. Before filling the tank make sure the tractor's PTO is disengaged. Fill the rinse tank with clean fresh water (only applicable with rinse tank option).
2. After filling the tank, open the main suction line valve located next to the strainer, below the tank. If your sprayer is equipped with a rinse system, reference the ball valve position decal (part #: DE42) to determine the correct ball valve positions (Figure 11, page 13). Engage

the pump by engaging the tractor's PTO system and allow for an ample amount of agitation time to mix the water and chemicals.

3. See chemical instructions for necessary agitation time.
4. Ensure that the ball valve located on the boom folding cylinder is in the closed position before transporting the sprayer (Figure 4, page 5). You are now ready to proceed to the desired spray location.

Operating Instructions

During Operation

1. Upon arrival at the desired location, open the ball valve at the rear hydraulic cylinder to the open boom operation position (Figure 4, page 5).
2. Adjust the ball valves to the spraying position (Figure 11).
3. Start the tractor, check for any obstructions, and extend the boom to the fully extended position by using the tractor's hydraulic controls.
4. Use the tractor's hydraulic controls to raise and level the boom to the desired spray height. Please note: The sprayer's boom can extend to the ground, which could potentially cause damage and void the manufacturer's warranty. Be aware of any obstructions that could damage the boom.
5. If the hydraulic boom is not operating smoothly, or it is operating too quickly, you may need to adjust your tractor's hydraulic flow.
6. Engage the sprayer's pump by engaging the tractor's PTO system. The tractor should be running at the RPM rate determined when you calibrated your sprayer. Ensure that the pump is primed and that there are no leaks in any of the hoses.
7. Using the pressure adjustment on the sprayer's control (either the pressure knob on manual control or the pressure toggle switch on the electric control), adjust the sprayer's pressure to the pressure rating found when you calibrated your sprayer. The sprayer's pressure can be found by looking at the pressure gauge located on the sprayer's control. Note: When you open the boom sections, the pressure may fluctuate.
8. To engage the boom sections, you need to turn on the boom sections using the sprayer's controls. On the electric control, the boom sections are labeled

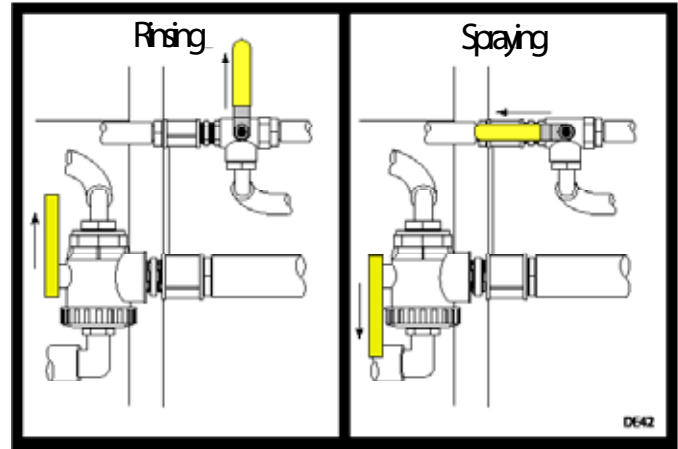

Figure 11: Ball valve position decal (DE42)

- numerically on the control box and are turned on using the toggle switches. On the manual control, the boom sections are engaged by flipping the levers.
9. You are now ready to begin spraying. Remember to drive the same speed which was used during calibration. During spraying a hydraulic boom can be raised and lowered as needed. It is also acceptable to run any combination of boom sections at a time.
10. Upon completion of spraying or if the tank is empty, turn off the boom sections using the sprayer's control. The electric control box is equipped with a master switch, which turns off all of the booms. Please note: Turning off the boom sections while the pump is engaged will cause the pump's pressure to spike. Be aware of your pump's maximum operating pressure so as not to exceed this and void the manufacturer's warranty.

Operating the Rinse System (only applicable with Rinse System option)

1. Following spraying, it is important to rinse out the sprayer's tank, rinsing can be completed with the help of the rinse system.
2. First, close all boom sections, disengage the pump, and turn off the tractor before adjusting the sprayer.
3. The ball valves need to be adjusted to the rinse position. The correct ball valve position is found on the side of the rinse tank mount (Figure 11, page 12).
4. Engage the pump with the tractor's engine running at half-throttle. When the rinse tank is empty, disengage the pump, and change the ball valves to the spray position. Engage the pump and spray with all three boom sections until the system is completely cleaned out. Excess water can be drained by removing the bowl of the in-line filter located below the tank (Figure 12, page 14).

Operating Instructions

Following Operation

1. Before transporting the sprayer, the boom needs to be completely closed. Close the hydraulic locking valve near the rear hydraulic cylinder (if applicable) to allow for safe transportation of the sprayer.
2. Before storing the sprayer ensure that the sprayer's tank, pump, and boom are completely rinsed out. This can be done by using the rinse system (if applicable) or by manually rinsing the sprayer's tank and running the clean water through the sprayer's boom until the system is completely rinsed out. Excess water can be drained by removing the bowl of the in-line filter located below the tank (Figure 12).
3. Before removing hydraulic hoses, move the tractor's levers to release any hydraulic pressure. Unhook the sprayer and store the sprayer on a hard level surface in a location away from human and livestock activity.

Maintenance Instructions

Routine Maintenance

It is very important to perform routine maintenance on your sprayer before and after each use. Good maintenance practices will help to guard against any sprayer breakdowns or accidents.

1. It is recommended to perform a visual and physical inspection for any worn parts, loose bolts, damaged hoses, or other visible problems. Make all necessary repairs before spraying. To order parts or receive technical help, please contact your local CropCare® dealer.
2. After each use it is important to rinse the pump and all components by running water through the system.
3. The in-line filter screen, located below the tank on the suction line, should be taken out and rinsed (Figure 12).
4. Note: Be careful not to lose the gasket in the filter bowl (Figure 12). A missing gasket will cause the strainer to leak.
5. Tip strainers should also be taken out and rinsed on a regular basis. Tip strainers are the small screens located behind each spray nozzle on the boom (Figure 13).
6. Grease the sprayer's grease points (Page 14) with general-purpose lithium grease on a regular basis.

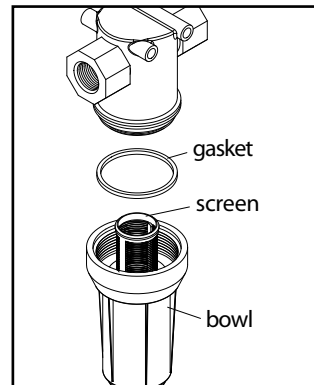

Figure 12: In-line filter

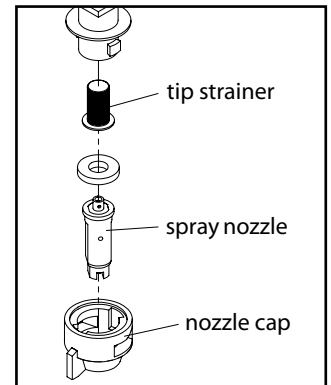
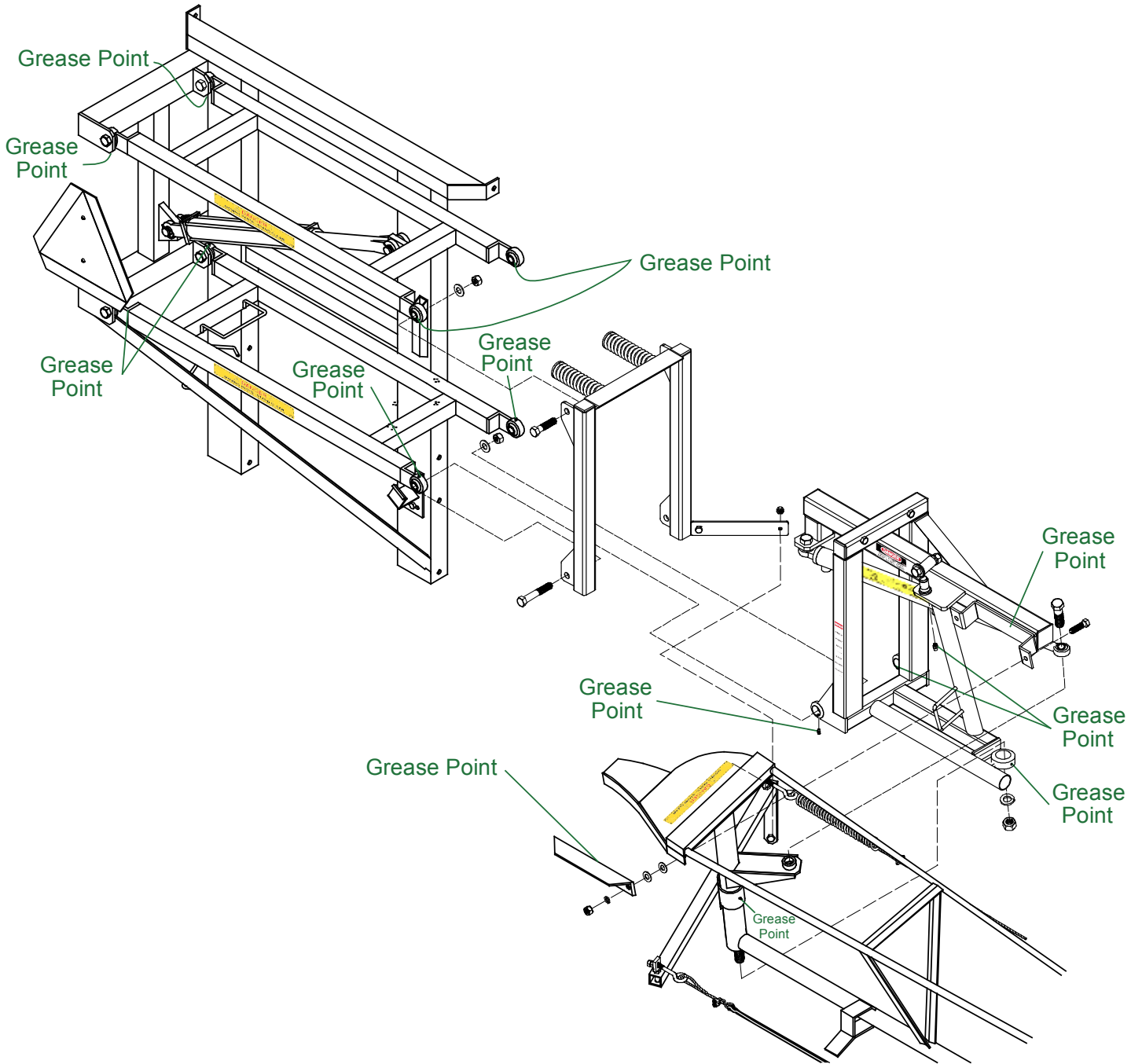

Figure 13: Nozzle breakdown

Maintenance Instructions

Grease Points



Maintenance Instructions

Pump Maintenance

1. Follow all pump safety precautions and warnings (page 7). Following these guidelines will help to ensure many years of smooth and trouble-free pumping.
2. Always flush the pump out with fresh water after every use. It is also very important to winterize your pump to prevent freezing and corrosion. See below for the winterizing instructions.
3. Hypro recommends changing the pump oil after 40 hours of break-in operation and every 500 hours or three months, whichever comes first. Use Hypro oil (part # 2160-0038).
4. To Drain the oil from the pump, remove the drain plug and rotate the shaft until the oil stops flowing out. To fill the pump with oil, slowly pour the oil into sight tube while turning the pump shaft. Turning the pump shaft purges all the air out of the crankcase. Always change the oil when replacing diaphragms.
5. Hypro recommends changing the diaphragms every 500 hours or three months, whichever comes first.
6. Refer to your pump owner's manual for service instructions, or contact your local CropCare® dealer.

Winterizing your Sprayer

It is essential that you winterize your sprayer to avoid damage and to allow for optimal performance. The winterization process should be undertaken before freezing conditions and/or after each season of use. Failure to winterize your sprayer will void the manufacturer's warranty.

1. Verify that the tank is empty and rinsed out. Pour 6 gallons of RV nontoxic antifreeze into the tank. It is not recommended to use standard antifreeze. Standard antifreeze can be harmful to humans, animals, crops, and the environment.
2. Engage the pump and pump the RV antifreeze through the entire system. Ensure that the antifreeze has been pumped through the entire system. When using a rinse system, pour the RV antifreeze into the rinse tank and pump through the rinse system and subsequently the boom.
3. Store the sprayer in a safe, dry location away from the elements and human and animal activity.
4. Before spraying in the spring, it is recommended to flush the sprayer with fresh water to cleanse it of the antifreeze and any other buildup.
5. Do a thorough inspection of all sprayer components before spraying.

Note: Do not, under any circumstances, run any petroleum based substance (such as diesel fuel) through the sprayer. This will cause damage to sprayer components and will void the manufacturer's warranty.

CropCare® Limited Warranty

High Pressure Produce Sprayer: Model TR300S

Warranty Coverage

CropCare® hereby provides a Limited Two (2) Year Warranty on Trailer Sprayers, manufactured by CropCare®. Trailer Sprayers manufactured by CropCare® are warranted against any manufacturer's defects in any of the sprayer's components in the 24 months following the original date of purchase.

Defective components will be repaired or replaced at the discretion of the manufacturer. It is the responsibility of the purchaser to return warranted components to the manufacturer. This warranty is limited to the repair or replacement of sprayer components only. CropCare® is not to be held liable for incidental or consequential damages of any kind. This warranty covers the purchaser of this sprayer and any other owners who own it during the two year warranty period.

To retain the warranty, the sprayer must be operated and maintained as ascribed by its owner's manual. For warranty service, please have a copy of the purchase invoice available.

Warranty Is Void if:

1. The sprayer has been subjected to, in the opinion of CropCare®, negligent handling, misuse, an accident or if the instructions in the owner's manual were not completely followed.
2. The sprayer's components have been altered in any manner or repairs have taken place with unapproved parts.
3. The sprayer and its components were subject to freezing or freezing conditions. The sprayer must have been winterized as per the maintenance instructions to retain the warranty.
4. A non-compatible chemical was used and/or if the sprayer operator failed to rinse all chemical residue out of the sprayer's components after use.
5. A petroleum-based, oil-based, or flammable product was used and caused damage to the pump, tank, hoses, or any other component.
6. The hitch pin was not placed an equal distance from the PTO U-joint and the pump U-joint.

Getting Service

All trailer sprayer warranty claims must be made through an authorized CropCare® dealer. All warranty claims must be submitted with an invoice or a proof of purchase that denotes the purchase date and place of purchase. If you have any questions or comments concerning this warranty, please contact an authorized CropCare® dealer.

Contact Us

We desire to give you continuing service in the best manner possible. This includes listening to your comments, suggestions, and problems. We will do our best to answer all questions thoroughly and in a timely manner. We have trained customer service specialists who are more than willing to listen to any questions or problems and help you to find a feasible solution.

Ordering Parts

Your CropCare® dealer has a fully-stocked parts department that will be able to meet all of your parts needs. Trained customer service specialists will ensure that all purchases are processed smoothly and shipped in a timely manner.

The logo for CropCare, featuring the word "CROPCARE" in a bold, green, sans-serif font. The letters are slightly slanted to the right. Below the text are two horizontal lines, one red and one green, with a small registered trademark symbol (®) to the right of the bottom line.

Manufactured by PBZ LLC
A Paul B Zimmerman Inc. Company

295 Wood Corner Road
Lititz PA 17543
(717) 738-7365
Fax (717) 738-7375
www.CropCareEquipment.com